

GLASS DOOR MERCHANDISER REFRIGERATORS

MODEL: MXM1-16RHC-50



MXM1-16RHC-50

Maxx Cold Glass Door Merchandisers are designed for durability and visual appeal to display your product. The glass door merchandisers are energy efficient and effective at displaying product at the right temperature to preserve freshness and prolong shelf life. Simple-to-use, programmable solid-state digital controls deliver accurate temperature regulation.

FEATURES AND CONSTRUCTION

- Constructed of a powder coated steel exterior and powder coated aluminum interior
- Double pane insulated glass door
- Interior LED lighting
- Bottom mounted compressor
- Three (3) adjustable heavy-duty PE-coated wire shelves
- Four (4) rollers (2 with leveling feet)
- Digital controls with LED temperature display
- Automatic defrost system
- Provided with lock and key set for security
- Illuminated top panel for advertising/promoting products
- Equipped with integrated condensate evaporator therefore no drain line connection is needed

ELECTRIC

230V / 50Hz / 1Ph

NOMINAL STORAGE CAPACITY

MXM1-16RHC..... 14.5 Cu Ft (411 L)

3RD PARTY APPROVALS



TEMPERATURE

Holding temperature 33°F to 41°F (1°C to 5°C)

- Oversized refrigeration system delivers optimum storage temperature and rapid temperature recovery

MXM1-12RHC-50

FRONT VIEW

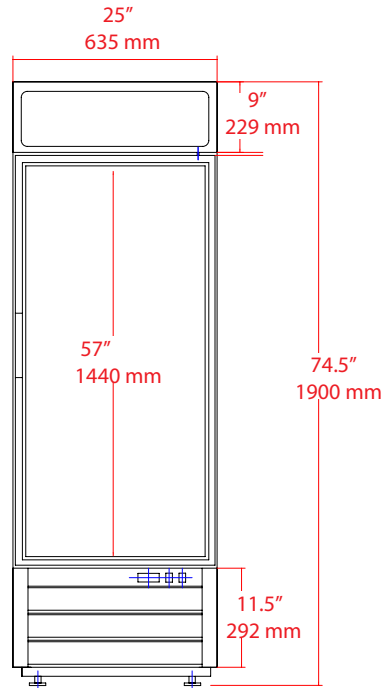

TOP VIEW

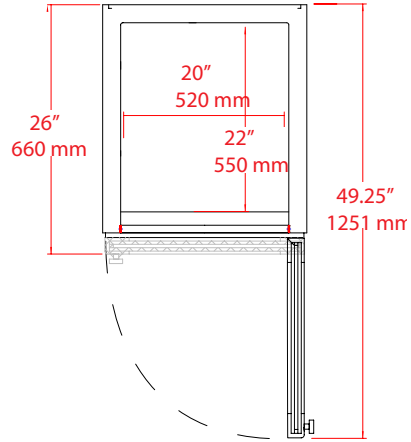

BACKLIT DISPLAY PANEL

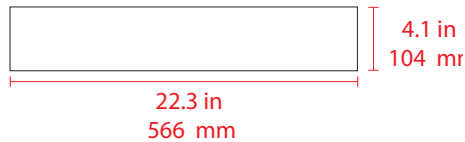

MODEL	EXTERNAL DIMENSIONS	INTERNAL DIMENSIONS	NOMINAL CAPACITY	HOLDING TEMPERATURE RANGE	AMP DRAW	UNIT WEIGHT	REFRIGERANT AND CHARGE SIZE	DOORS / SHELVES	ELECTRICAL
MXM1-16RHC-50	25" x 26" x 74.5" (635 x 660 x 1900 mm)	20" x 22" x 57" (520 x 550 x 1440 mm)	14.5 Cu Ft (411 L)	33°F to 41°F (1°C to 5°C)	2.3A	243 lbs (110 kg)	R134A 11.99 oz (340 g)	1 / 3	230V / 50Hz / 1Ph

INSTALLATION

- Units are equipped with roller wheels and leveling feet. Swivel caster wheels are an available option for increased mobility.